



EU-TYPE EXAMINATION CERTIFICATE

Number: TCM 311/18 - 5583

Page 1 from 9 pages

In accordance: with Directive 2014/32/EU of the European Parliament and of the Council on the harmonisation of the laws of the Member States relating to the making available on the market of measuring instruments (implemented in Czech Republic by Government Order No. 120/2016 Coll.).

Manufacturer: Teplovodokhran Ltd.
Novaya str. 51v
390027 Ryazan
Russia

For: Mechanical heat meter - compact
Type: Pulsar M

Accuracy class: 3

Valid until: 9 September 2028

Document No: 0511-CS-A033-18

Description: Essential characteristics, approved conditions and special conditions, if any, are described in this certificate.

Date of issue: 10 September 2018

Certificate approved by:



RNDr. Pavel Klenovský

1 Measuring device description

The compact heat meters type Pulsar M are designed to measure a heat energy which, in a heat exchange circuit, is given up by a liquid called the heat-conveying liquid in the sense of the Directive of the European Parliament and of the Council no. 2014/32/EC of measuring instruments, as amended.

The compact heat meters type Pulsar M consists of a mechanical single jet flow sensor, temperature sensor pair and electronic calculator.

Water flows in the measuring part, rotates impeller. The rotation is transmitting via metal plate on impeller and inductive coil, connected to electronic calculator. The adjustment of flow sensor is provided using calibration coefficients inside electronic calculator. Installation of flowmeter is marked by symbol on display of meter. It could be optional determined only one time before starting of meter into operation. It is more described in document "Installation and operating instruction".

Temperature sensor pair is soldered to PCB of electronic calculator. One temperature sensor is for inlet pipeline, another one is for outlet pipeline. One temperature sensor is installed in the flow meter and sealed. Another one must be installed in the pipe "opposite" to the flow meter.

The electronic calculator consists of PCB with lithium battery, LCD and one touch button. The calculator is assembled to plastic housing. Plastic housing consists of upper and bottom parts, connected with two sealed screws. It not possible to disassemble plastic housing without braking sealing. Plastic housing prevents access to electronics and temperature sensors connection. There is special jumper on PCB, which protects from changing calibration and configuration of metrological parameters.

The compact heat meters type Pulsar M can be equipped with different communication interfaces.

Equation for heat energy calculation is described by next basic formula:

$$Q = \int_{\tau_0}^{\tau_1} q_m \times \Delta h \times d\tau = \int_{\tau_0}^{\tau_1} \rho \times q_v \times \Delta h \times d\tau$$

Where are:

Q quantity of heat energy, units GJ or MWh, kWh

τ time of measurements, h

q_m mass flow-rate of the energy-conveying liquid passing through the heat meter, kg/m³

q_v volume flow-rate of the energy-conveying liquid passing through the heat meter, m³/h

ρ density of the heat-conveying liquid passing through the heat meter, kg/m³

Δh difference between the specific enthalpies of the heat-conveying liquid at the inlet and outlet temperatures of the heat-exchange circuit, J/kg.

Compact heat meters type Pulsar M are manufactured according to the technical documentation of the company Teplovodokhran Ltd. There are a following main documents: Installation and operation instruction, August 2018, Heat meter menu, February 2017, Assembling Pulsar, August 2018, Test Program TestAll2.55, June 2017, Test equipment of Teplovodokhran, March 2017. Manufacturing documentation Nr. 469445.086(0), September 2016.

Remark 1: HW and SW of Pulsar M compact heat meters are prepared for measurement of cool (absorbed) energy of heat-conveying liquid also. Tests of this cooling application concerning particular points of standard EN 1434-4:2015 were not subject of this Certificate.

Remark2: Pulsar M compact heat meters can optionally display a value of measured energy in unit Gcal also. Testing of values in this unit was not subject of this Certificate.

2 Basic technical data

2.1 Flow sensor

Table 1:

nominal diameter	DN15	DN15	DN15	DN20	DN20
Minimum flow q_i , m ³ /h (horizontal/vertical)	0,012/0,060	0,02/0,1	0,03/0,150	0,03/0,150	0,05/0,250
Nominal flow q_p , m ³ /h	0,6	1	1,5	1,5	2,5
Maximum flow q_s , m ³ /h	1,2	2	3	3	5
Thread	G3/4B	G3/4B	G3/4B	G1B	G1B
Length, mm	110	110	110	130	130
Dynamic range q_i/q_p	1:50 horizontal, (1:10 for vertical installation)				
Ambient temperature, °C	5..55				
Pressure loss at q_p , bar	< 0,2				
Accuracy class (EN1434)	3				
Nominal pressure, maximum pressure, bar	16				
Liquid specification	water				
Direction of flow	one direction				
Temperature range, °C	0..90				
Installation	Return flow/forward flow/horizontal/vertical				
Flow profile sensitivity classes	U3, D3				

2.2 Calculator, temperature sensors

Table 2:

Temperature range, °C	0-105
Temperature difference range, K	3-90
Temperature solution, °C	0,01
Ambient temperature, °C	5-55
Protection	IP65
Environmental class	A
Electromagnetic class	E1
Mechanical class	M1
Display	LCD, 8 digits
Units	MWh, kWh, GJ
Power supply	3,6 V , lithium battery, 10 years
Temperature sensors	Pt1000
Length of cable , m	1,5
Material of pocket	Stainless Steel
SW version, CRC	SW version F.2 1, CRC F72A SW version F.1 8, CRC 4d1C SW version F.1 9, CRC 8Cd3

2.3 Interfaces of Pulsar M heat meters

Table 3:

User interface:	LCD display, button only for overview data
Communication interfaces, optional:	M-BUS, for currently reading RS 485, data reading, history, max. length of cable 1,2 m optical IR – infrared output pulses, open collector input pulses, 4 pulse types for external meters

3 Test

Technical tests of heat meters UHM were performed in compliance with the International Recommendation OIML R 75 Edition 2006 (E) and with conformity to EN 1434:2015.

EMC test and shock/vibration tests were performed in accordance with relevant points of standard EN 1434,-4:2015 and of document OIML D11:2013 (also in accordance with other relevant documents and standards).

SW validation was performed concerning relevant points of document WELMEC Guide 7.2.

Results of all performed tests are presented in: Test report Nr. 6015-PT-0045-18 from August 10th 2018, (main metrological and other tests), Test report Nr. 8553-PT-S1006-18 from May 15th 2018 (SW validation), 8551-PT-E0183-17 from September 11th 2017 (EMC tests), Test report Nr. 801663-01/01 of Electrotechnical testing institute Prague from May 17th 2018 (vibration tests).

4 The measuring device data

There are a following information on Pulsar M heat meter (resp. on LCD display):

- CE marking
- Number of EU-type examination certificate
- Manufacturer's mark or name, logo, address
- Year of manufacture
- Measuring device type
- The serial number
- Unit of measurement
- Accuracy class 3
- Environment class: A
- Mechanical environment: M1
- Electromagnetic environment: E1
- Protection class: IP65
- Nominal pressure PN, max pressure PS
- Range of temperature measurements
- Range of temperature difference measurements
- Limiting values of flow rate
- Place of the flow sensor installation (inlet, outlet, resp. flow, return)
- Flow profile sensitivity classes: U3, D3
- Arrow concerning a flow direction on the meter body
- SW version and CRC value

5. Inscriptions, sealing, CRC marking, assembling

Inscription on Pulsar M heat meter concerning over point 4, and other necessary information are presented on pictures from 1 up to 3.

Direction of flow on the body of flowmeter, picture 4.

Security, resp. installation seals are specified on pictures 5 and 6.

On picture 7, an examples of latest SW versions F.2.1 and F.1 9 are given.

Picture 8, CRC value for SW version F.1.9

Assembling of Pulsar M meters, see you pictures 9 and 10.

Symbol, installation of flowmeter, return pipe



Pict. 1, inscription on Pulsar M heat meter (unit of measurement GJ, number of EU Certificate, main metrological label, other important information)



Pict. 2, address of manufacturer

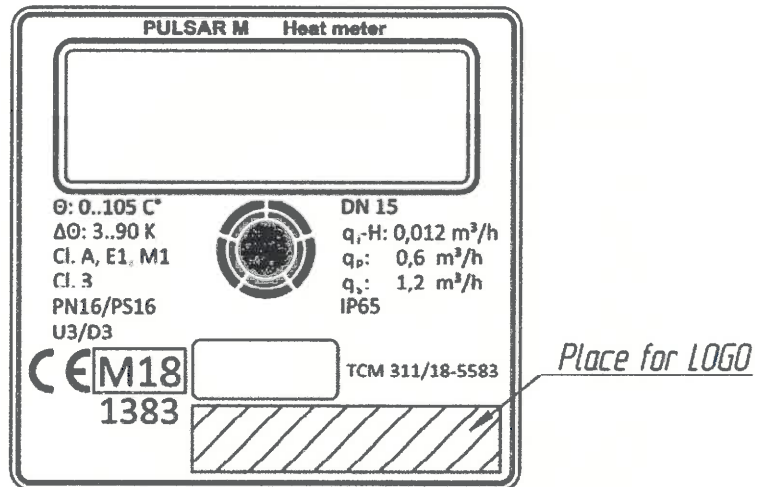

Pict. 3, place for event. other logo of Pulsar M heat meter



Pict. 4, arrow on the body of meter which determines a direction of flow

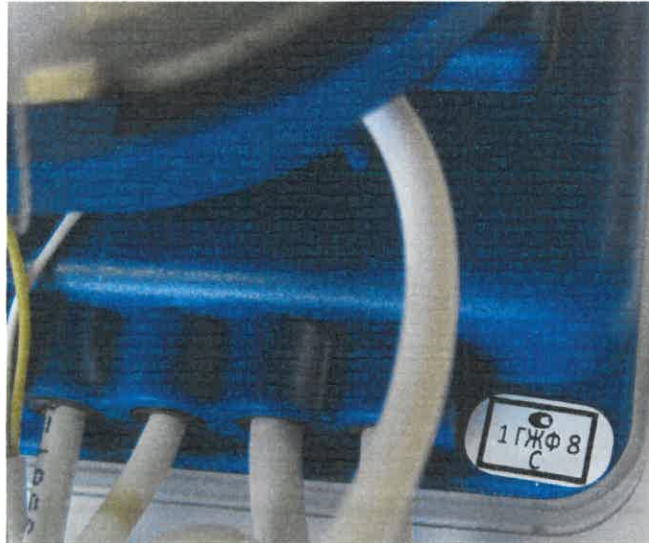

Pict. 5, Main security sealing (over a screw which connects plastic cover of a meter with the body)



Pict. 6, Installation seal which assure a connection of one temperature sensor with the body of meter



Pict. 7, Display with given SW versions

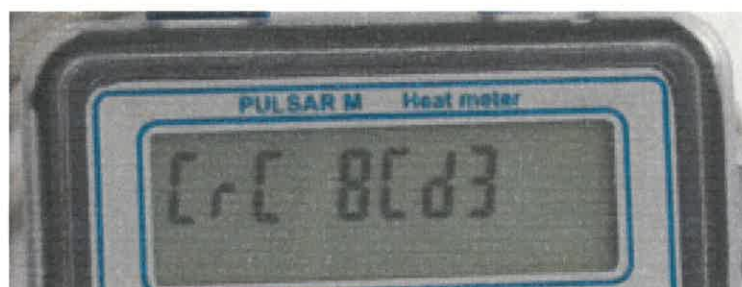

Pict. 8, CRC value for SW version F.1 9

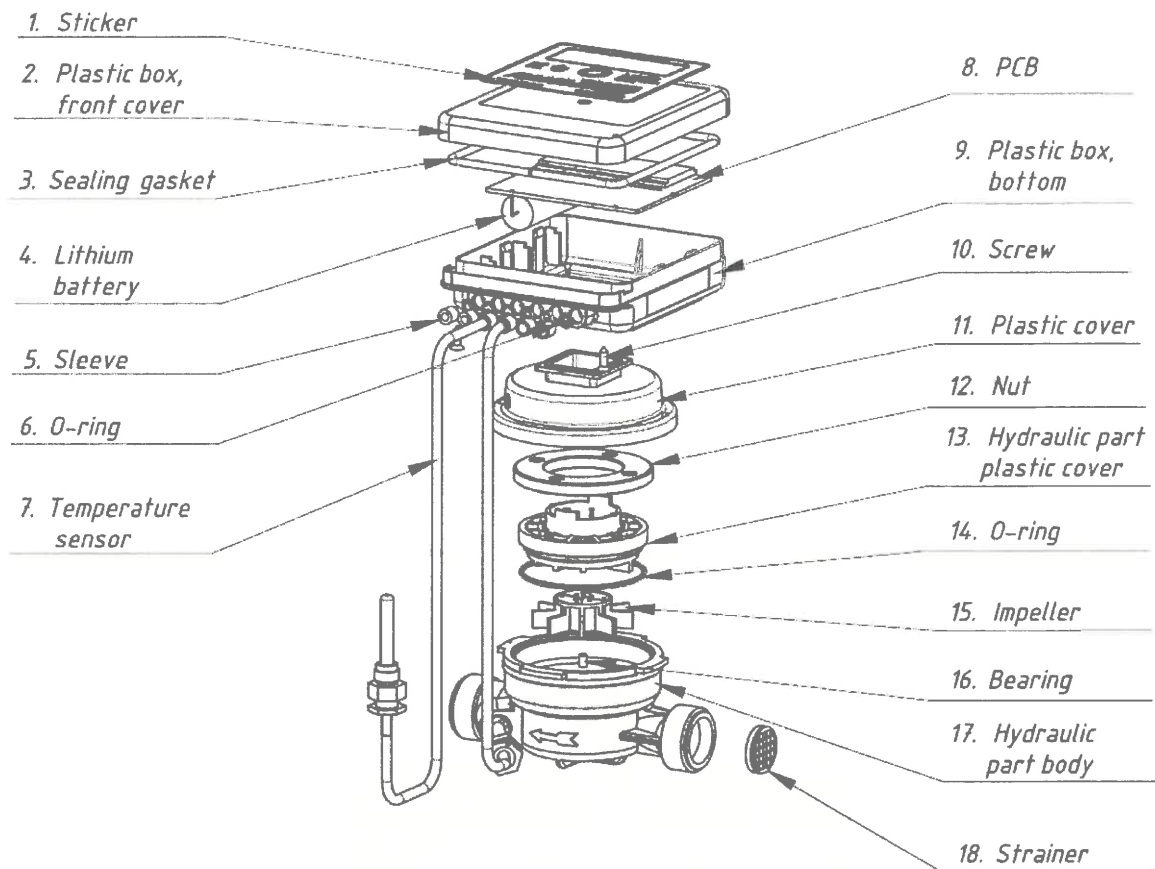

Pict. 9, assembling of Pulsar M compact heat meters

CODE	DESCRIPTION	MATERIALS
1	Sticker	PP
2	Plastic box, front cover	PC
3	Sealing gasket	THERMOELASTOPLAST
4	Lithium battery	ELECTRONIC PART
5	Sleeve	ABS
6	O-ring	NBR
7	Temperature sensor	ELECTRONIC PART
8	PCB	ELECTRONIC PART
9	Plastic box, bottom	ABS
10	Screw	STEEL
11	Plastic cover	ABS
12	Nut	BRASS
13	Hydraulic part plastic cover	PPS
14	O-ring	EPDM
15	Impeller	PP, tungsten carbide
16	Bearing	SAPHIRE
17	Hydraulic part body	BRASS
18	Strainer	PPS

Pict. 10, assembling of compact heat meters, continue, table